

# ERGO

Motoriduttore elettromeccanico interrato per cancelli a battente



Istruzioni per l'installazione l'uso e la manutenzione



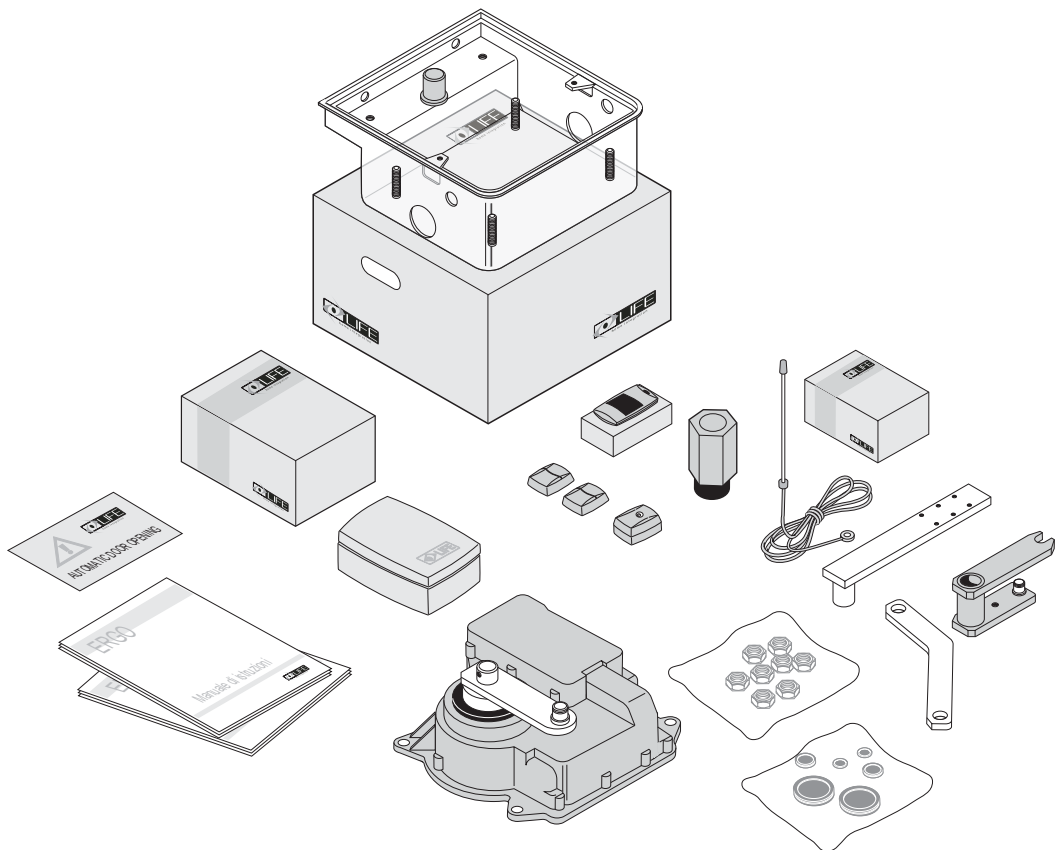
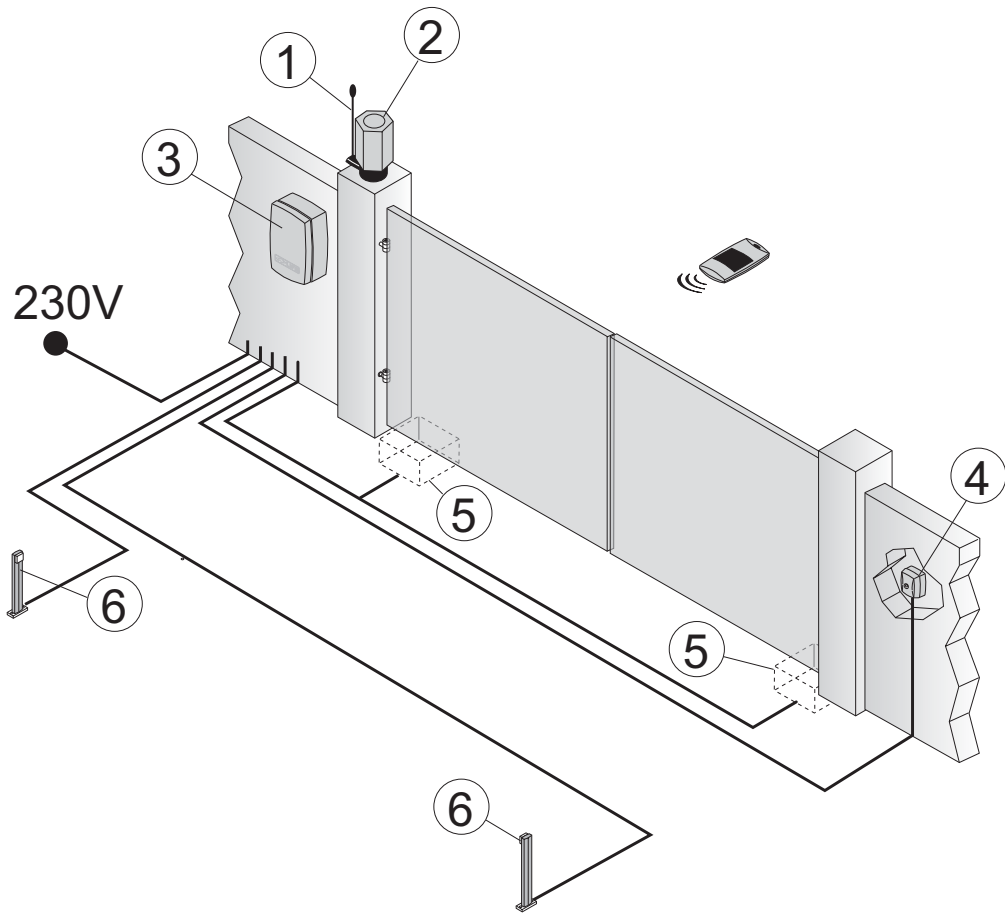

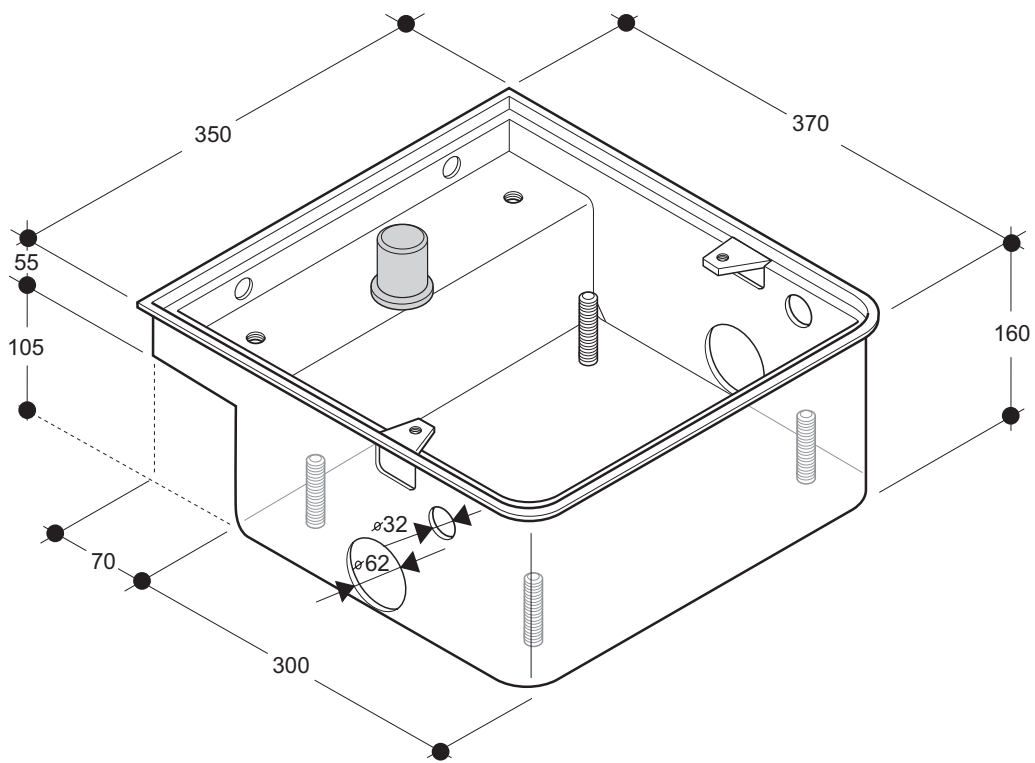

1

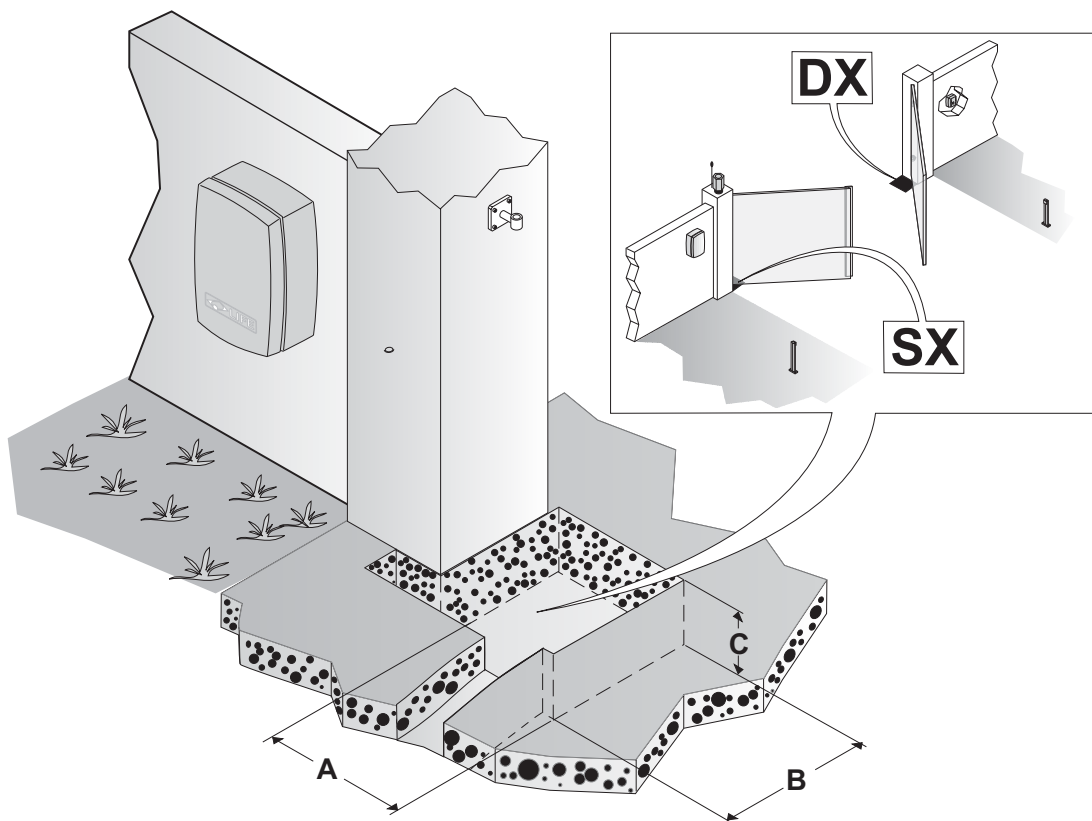

# 2

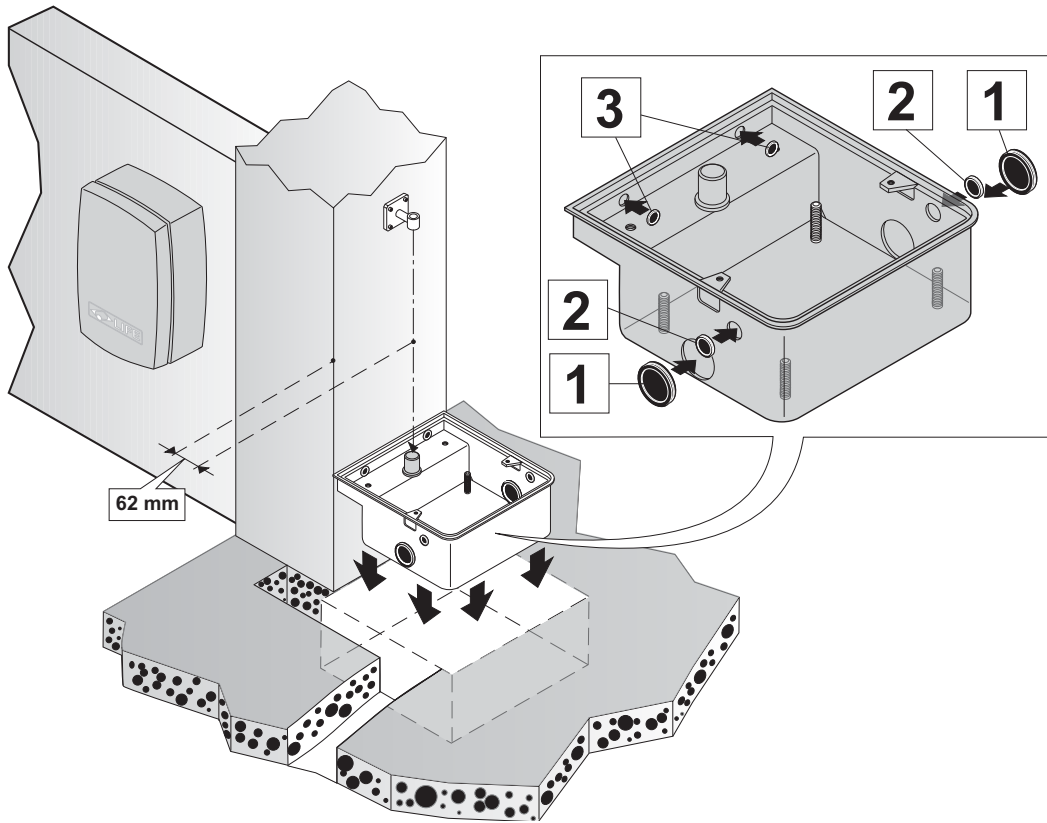

# 3

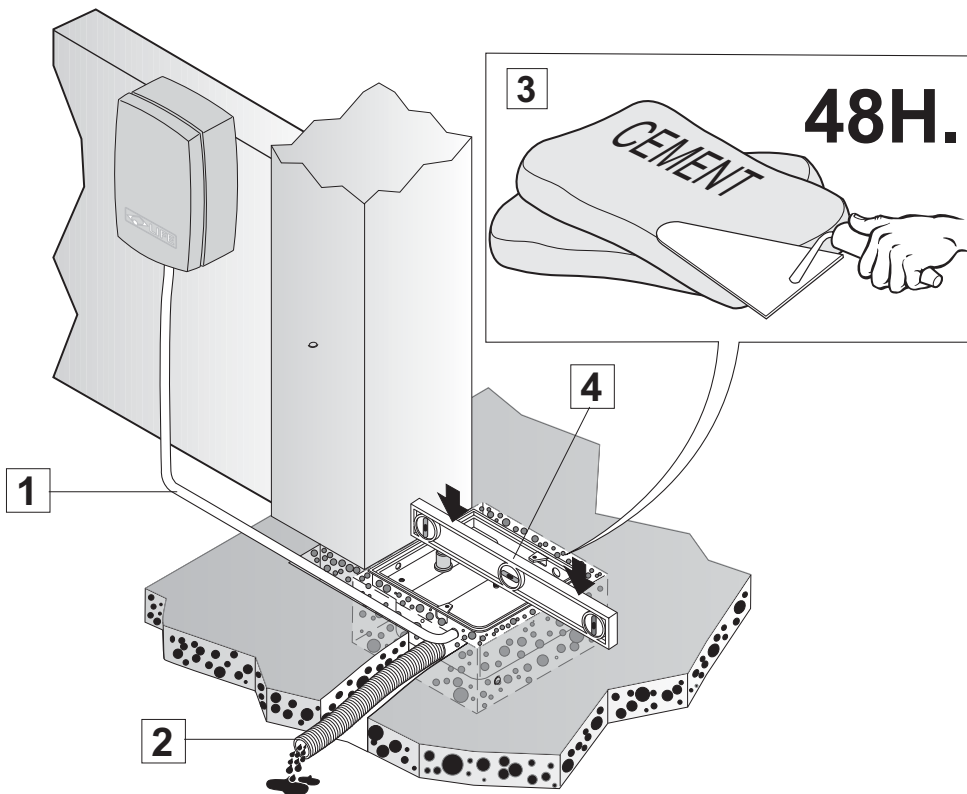

# 4 SX

# DX

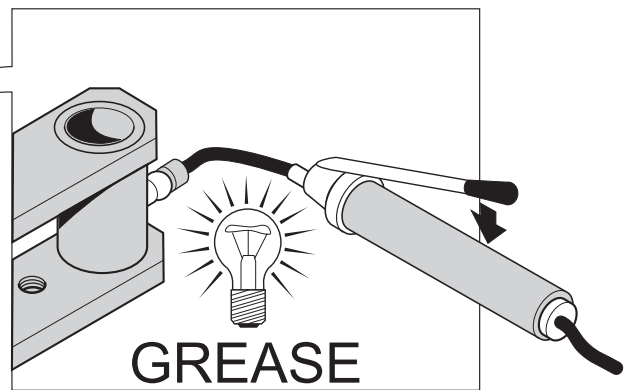
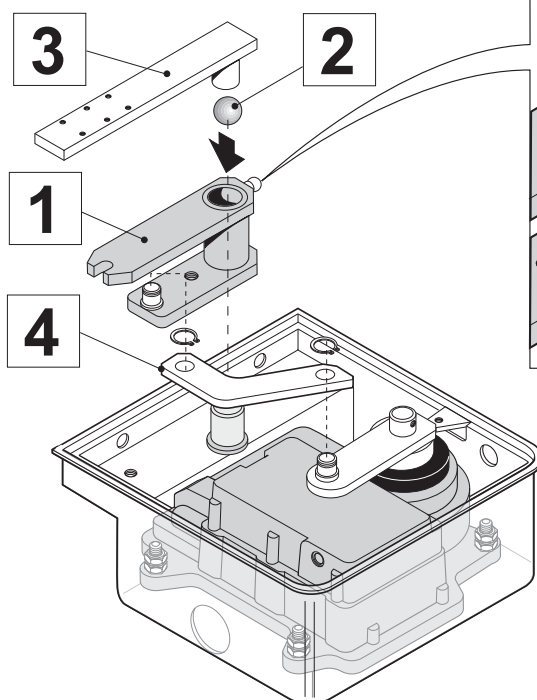
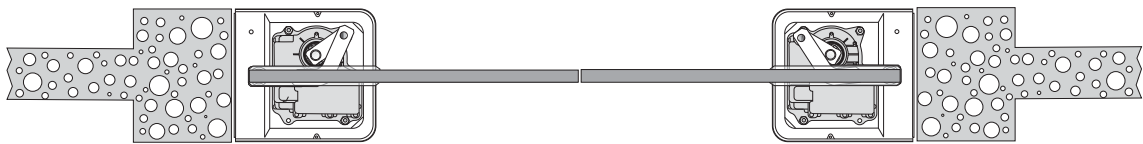
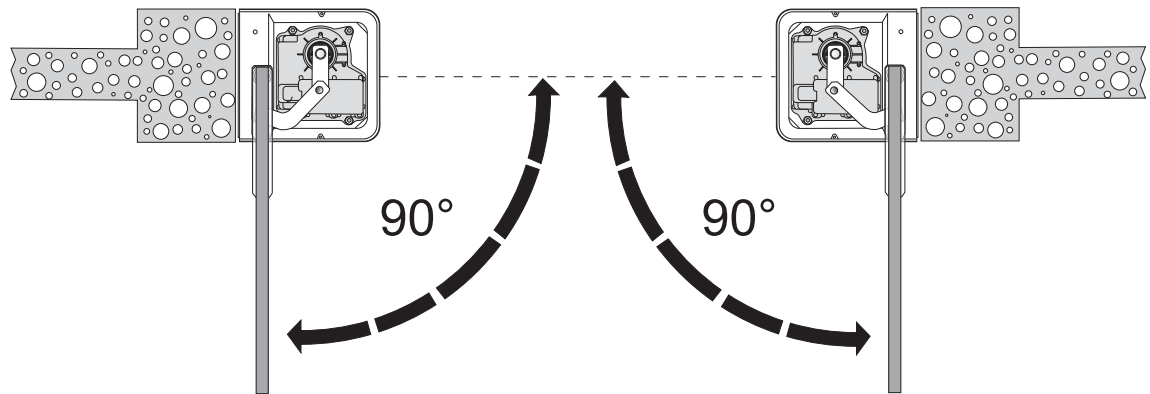
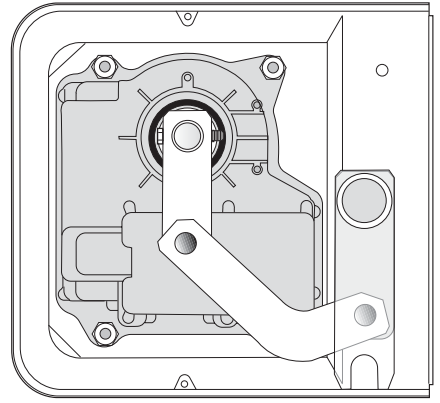
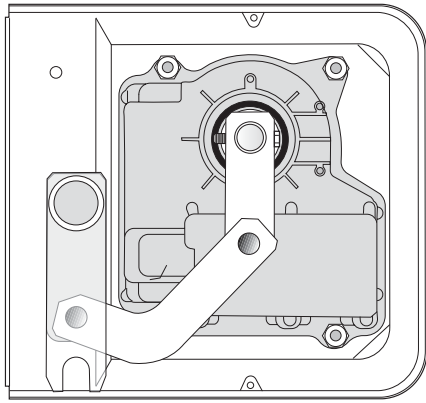

# AER 1

## 5 SX

## DX

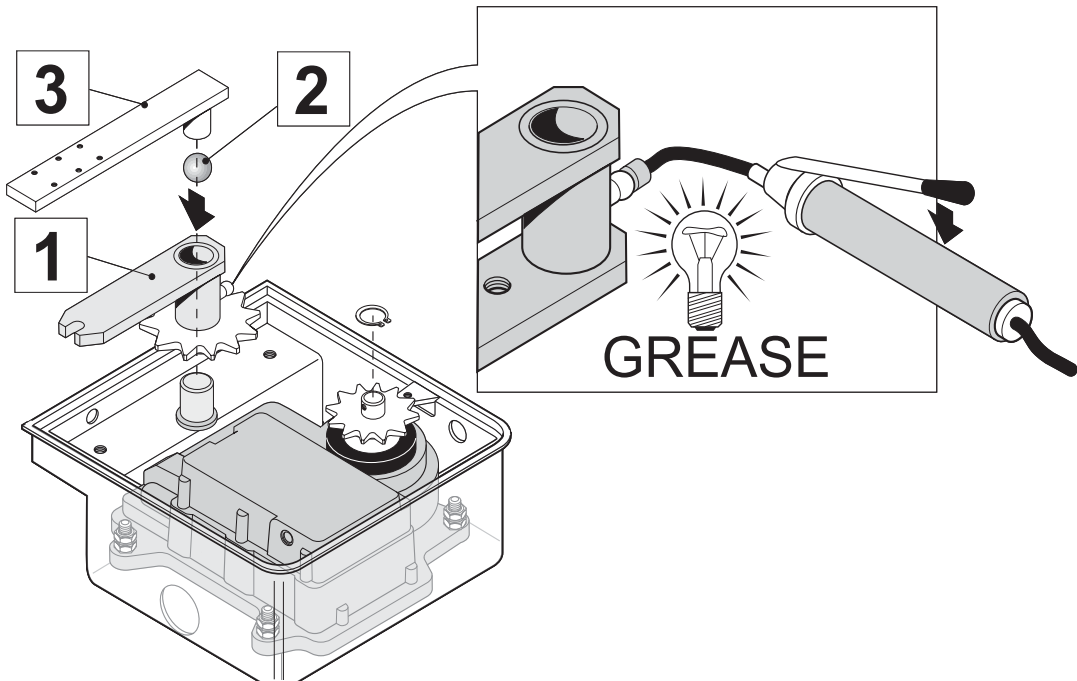
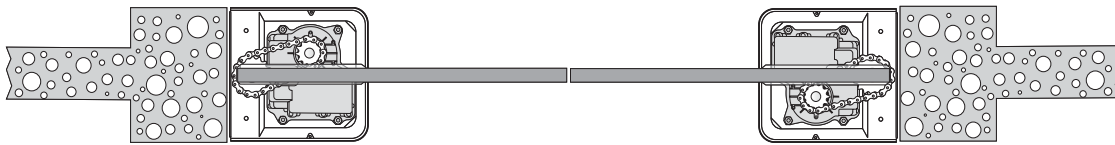
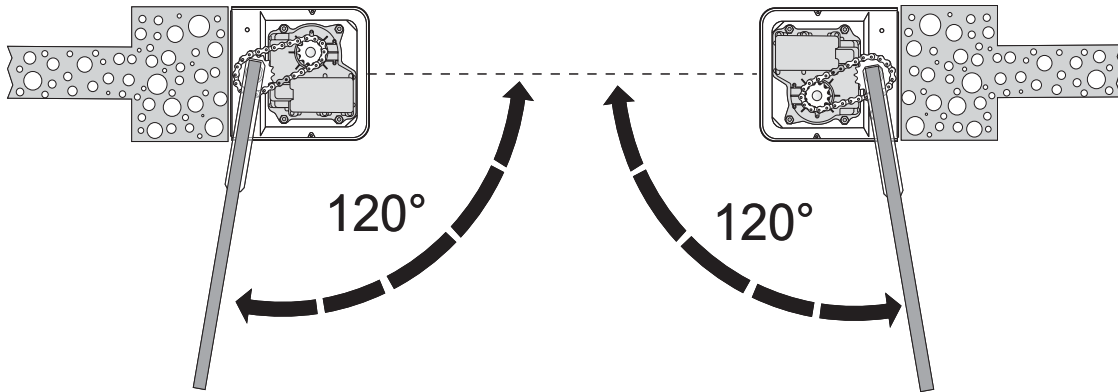
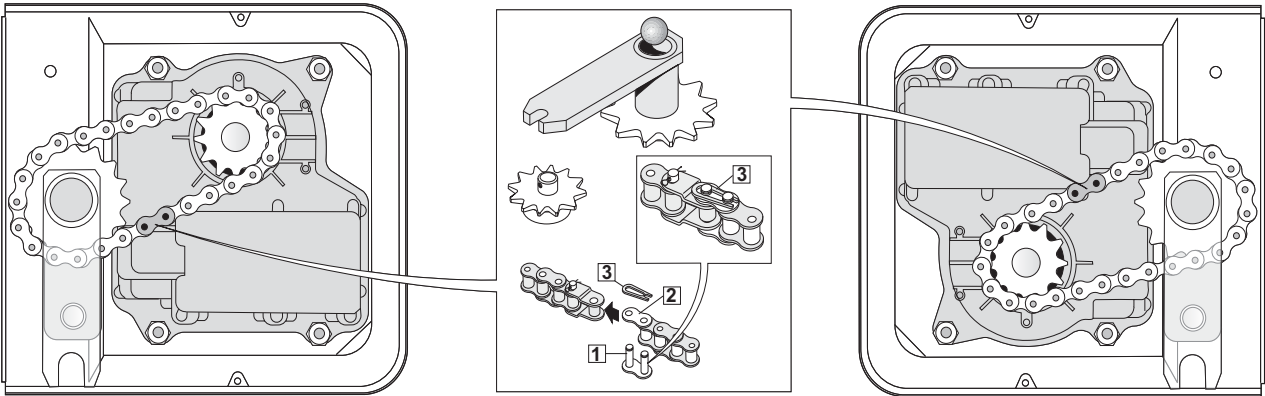

# 6 SX

# DX

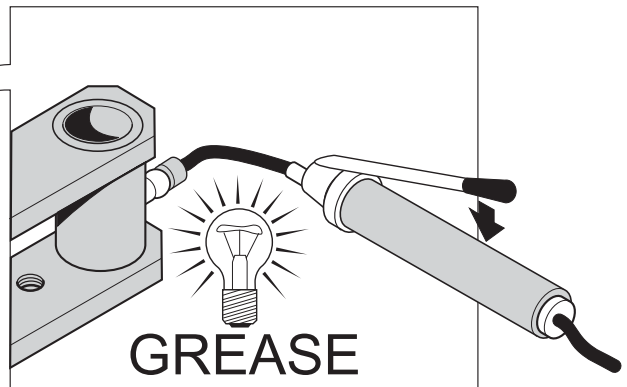
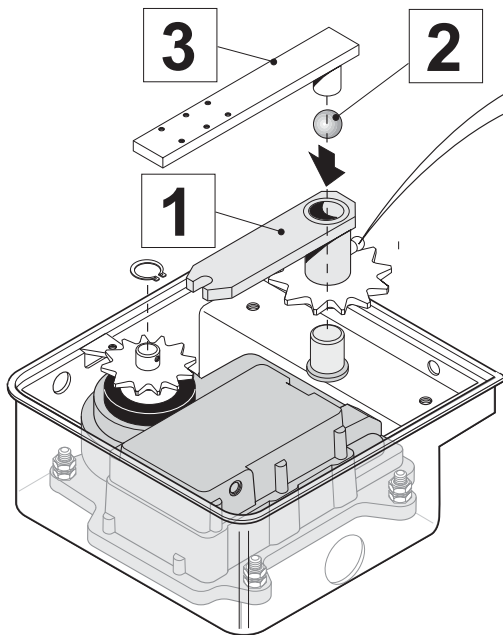
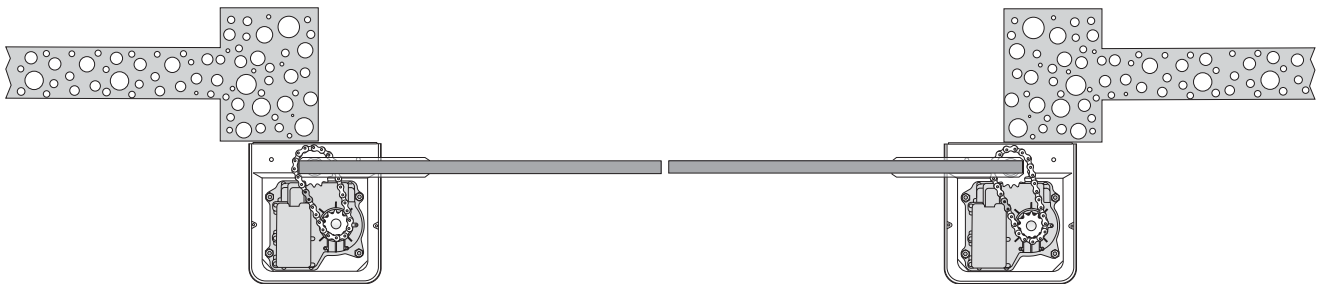
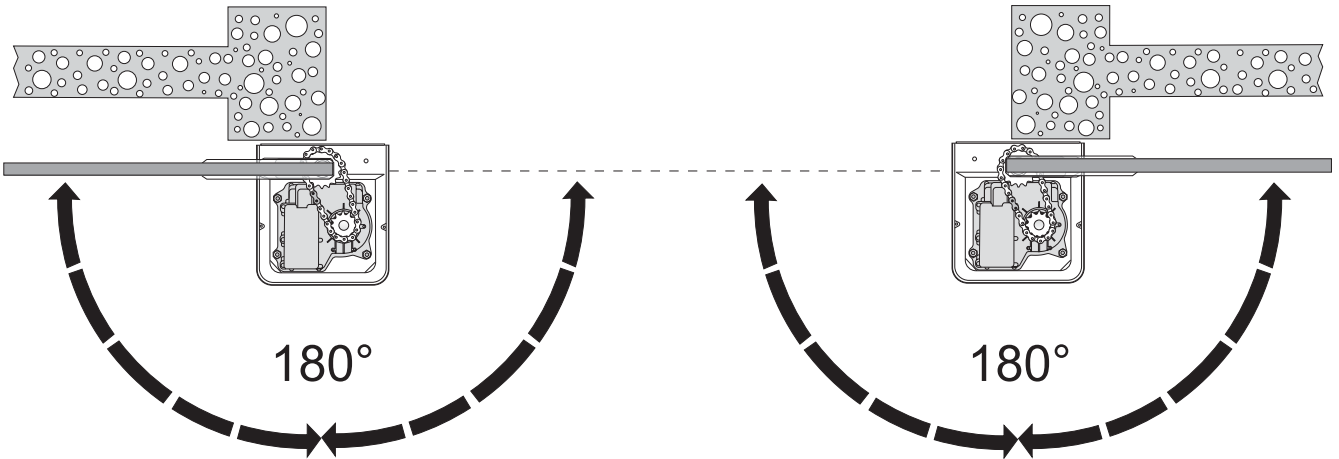
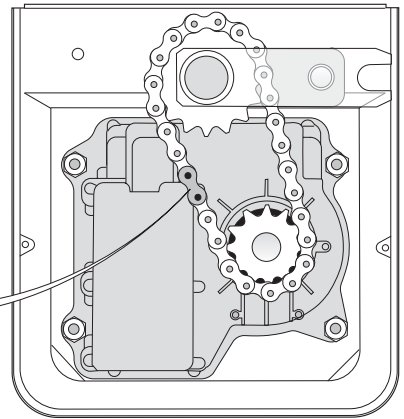
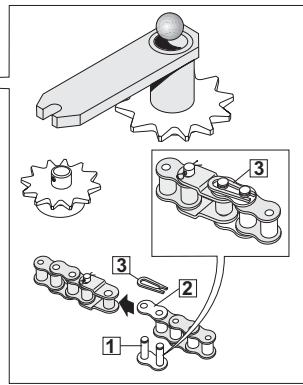
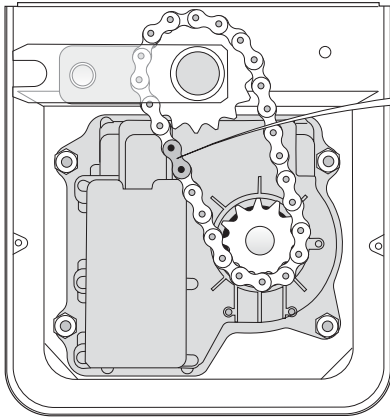

# 7

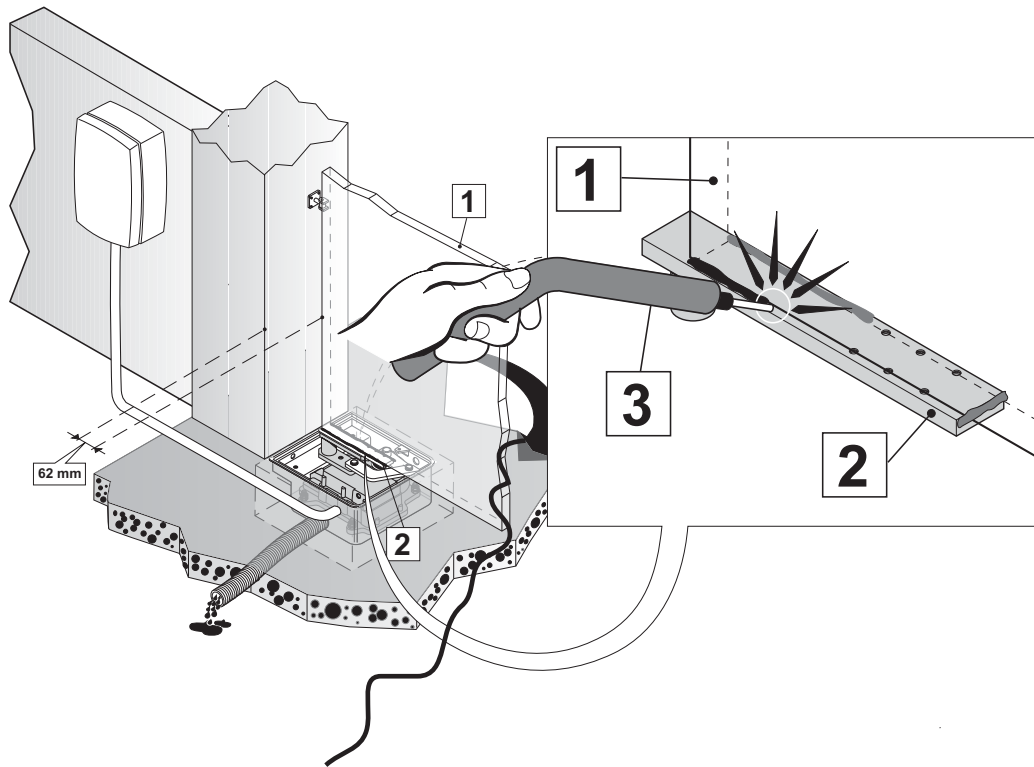

# 8

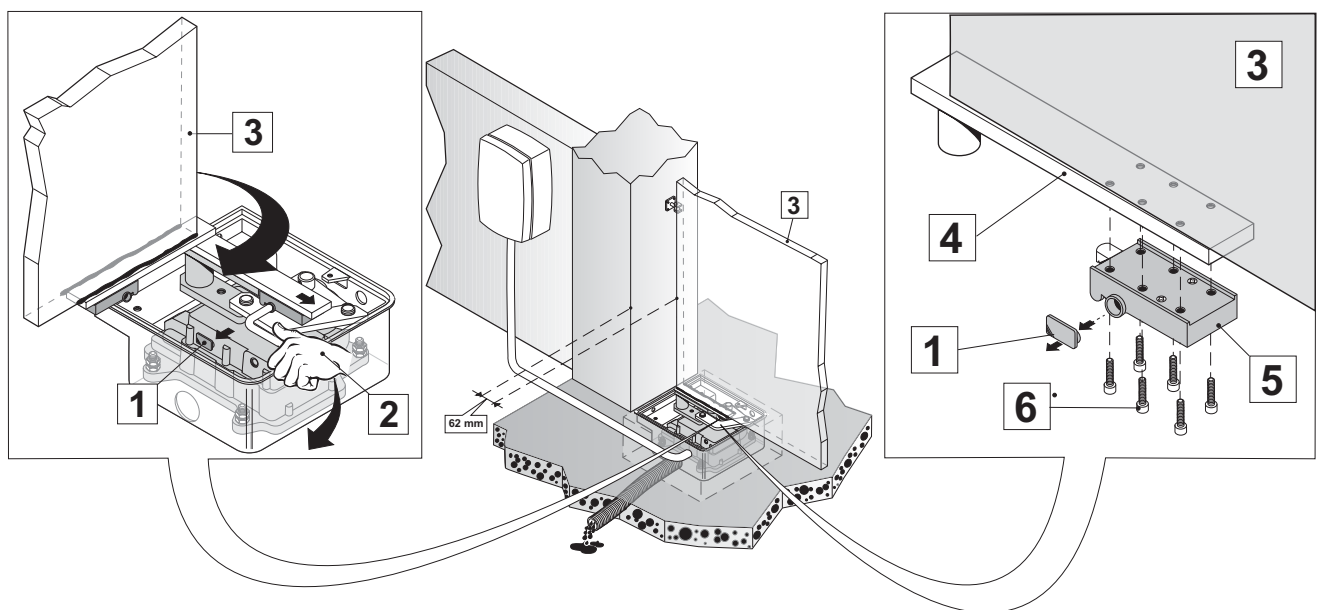



9

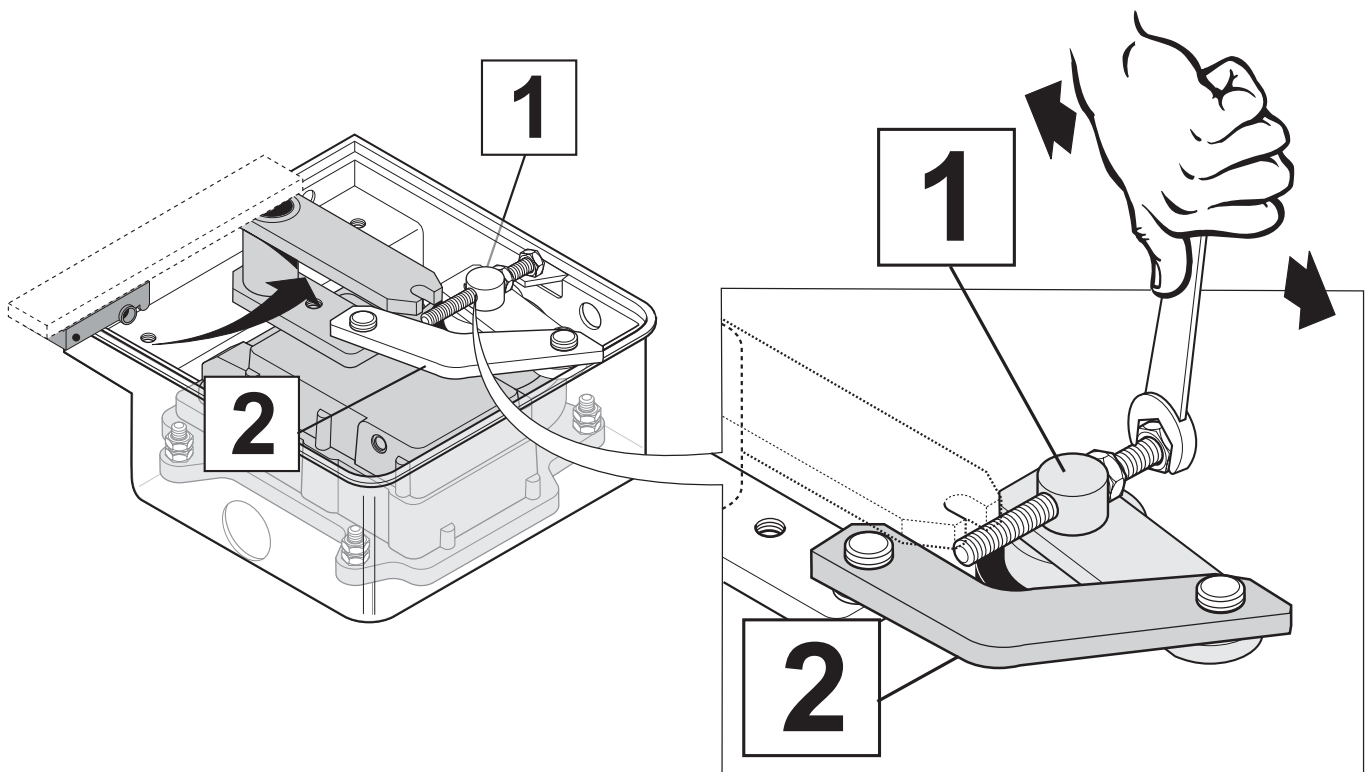
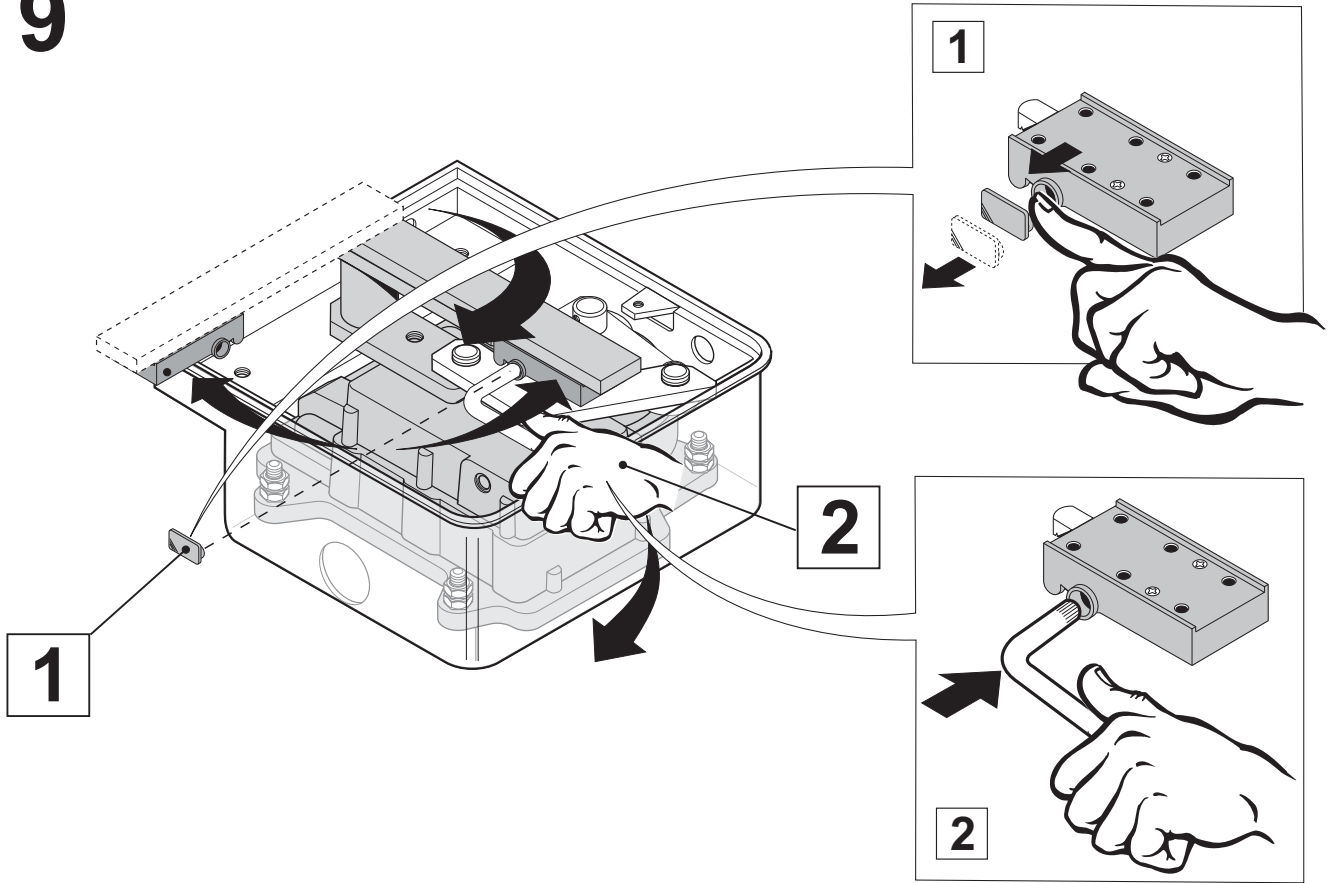

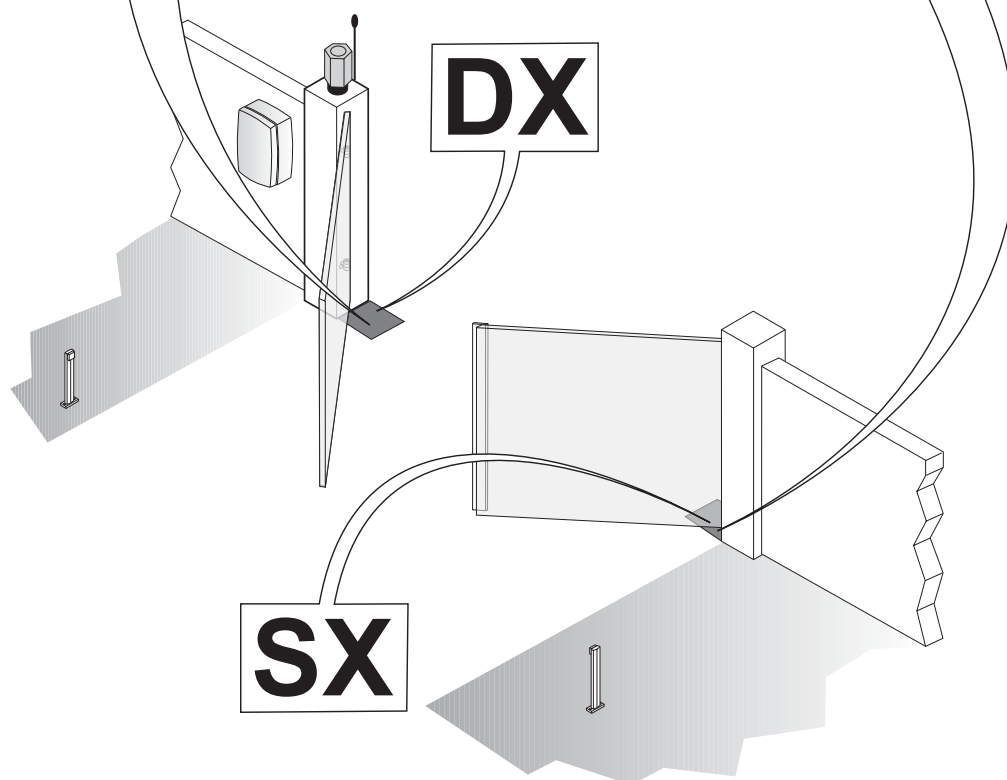
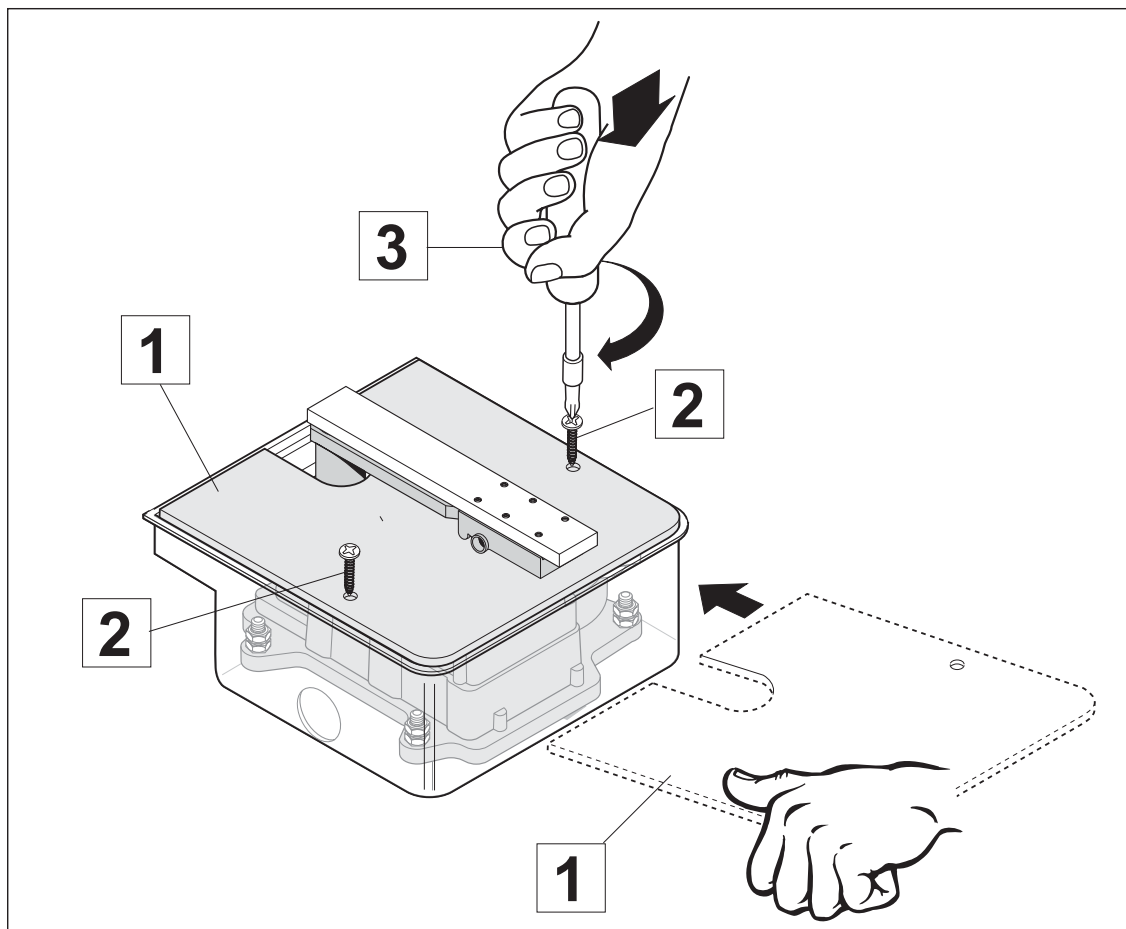

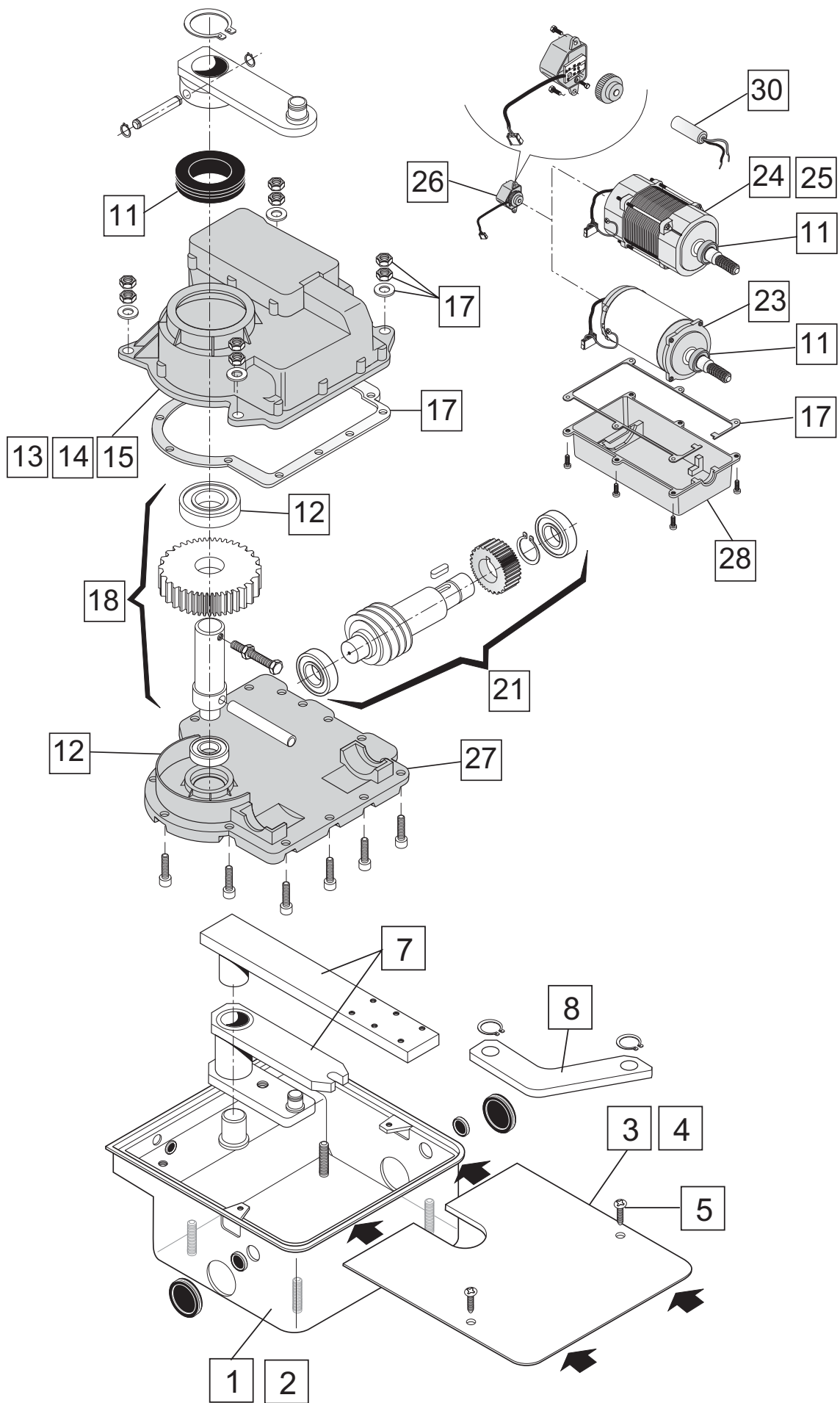

POSIZIONE	Codice	DESCRIZIONE
1	1AM0820000	ERG
2	1AM0830000	ERGX
3	5RI3200000	RICAMBIO COPERCHIO ERGX
4	5RI3210000	RICAMBIO COPERCHIO ERG
5	5RI0510000	RICAMBIO VITI FISSAGGIO COPERCHIO CASSA FONDAZIONE
7	5RI0520000	RICAMBIO GRUPPO LEVE
8	5RI0530000	RICAMBIO BIELLA COLLEGAMENTO
10	5RI0550000	RICAMBIO FERMO BATTUTA CON DADO
11	5RI0570000	RICAMBIO PARAOLIO GRANDE E PICCOLO
12	5RI0640000	CUSCINETTO GRANDE E PICCOLO
13	5RI0580000	RICAMBIO COPERCHIO: ER4-ER4L-ER424
14	5RI0590000	RICAMBIO COPERCHIO. ER4UNI-ER4UNIL
15	5RI0600000	RICAMBIO COPERCHIO: ER4B
17	5RI3220000	TAPPO 1/4 GAS TC2+RICAMBIO GUARNIZIONI MOTORE
18	5RI0630000	RICAMBIO ASS. ALBERO MOTORE E PIGNONE Z42 M3 H25
21	5RI0650000	RICAMBIO ASSIEME TRASMISSIONE
23	5RI0680000	MOTORE 24V (ER424)
24	5RI0660000	MOTORE 230V (ER4 / ER4UNI / ER4B)
25	5RI0670000	MOTORE 230V LENTO (ER4L / ER4UNIL)
26	5RI0610000	RICAMBIO ENCODER ER4 / ER4L
27	5RI0540000	BASE INTERRATO
28	5RI0620000	COPERCHIO MOTORE INTERRATO
30	5RI0640000	CONDENSATORE 12 <sub>mf</sub>

NOTE



# DICHIARAZIONE CE DI CONFORMITÀ DEL FABBRICANTE

## Dichiarazione di conformità



secondo Direttiva 98/37/CE, Allegato II, parte B (dichiarazione CE di conformità del fabbricante)

LIFE home integration  
Via Sandro Pertini, 3/5  
31014 COLLE UMBERTO (TV) – Italia

dichiara che il seguente prodotto:  
Motoriduttore per cancelli scorrevoli

## MOTORE ERGO

Risulta conforme ai requisiti essenziali previsti dalle seguenti direttive:

- Macchine 98/37/CE (ex 89/392/CEE) e successive modificazioni,
- Bassa Tensione 73/23/CEE e successive modificazioni,
- Compatibilità Elettromagnetica 89/336/CEE e successive modificazioni.

Risulta conforme a quanto previsto dalle seguenti norme:

- EN 12445:2000
- EN 12453:
- EN 6

Dichiara inoltre che non è c   
conforme alla direttiva 98/37/CE.

COLLE UMBERTO (TV)

Nominativo del Firmatario: Michele Rui

Qualifica: Presidente

Firma: \_\_\_\_\_



NOTE

---

---

---

---

---

---

---

---

---

---

---

---

---

---

---

---

---

---

---

---

---

---

---

---

---

---

---

---

---

---





Address: Via Sandro Pertini, 3/5 - 31014 COLLE UMBERTO(TV) Italia

Telephone: + 39 0438 388592

Telefax: + 39 0438 388593

http: [www.homelife.it](http://www.homelife.it)

e-mail: [info@homelife.it](mailto:info@homelife.it)

